



1000-4819

**FSP201
Datasheet**

Rev. 1.4

March 2026

Disclaimer and Proprietary Information Notice

The information contained in this document does not represent a commitment on any part by Ceva®, Inc., or its subsidiaries (collectively, "Ceva "). Ceva makes no warranty of any kind with regard to this material, including, but not limited to implied warranties of merchantability and fitness for a particular purpose whether arising out of law, custom, conduct, or otherwise.

Additionally, Ceva assumes no responsibility for any errors or omissions contained herein, and assumes no liability for special, direct, indirect, or consequential damage, losses, costs, charges, claims, demands, fees, or expenses, of any nature or kind, which are incurred in connection with the furnishing, performance, or use of this material.

This document contains proprietary information, which is protected by U.S. and international copyright laws. All rights reserved. No part of this document may be reproduced, photocopied, or translated into another language without the prior written consent of Ceva. All product names are registered trademarks of Ceva®, Inc. and/or its subsidiaries, or, of its applicable suppliers if so stated.

Support

Ceva® makes great efforts to provide a user -friendly software and hardware development environment. Along with this, Ceva provides comprehensive documentation, enabling users to learn and develop applications on their own. Due to the complexities involved in the development of IP applications that might be beyond the scope of the documentation, an online Technical Support Service has been established. This service includes useful tips and provides fast and efficient help, assisting users to quickly resolve development problems.

How to Get Technical Support:

FAQs: Visit our website <http://www.Ceva-ip.com> or your company's protected page on the Ceva website for the latest answers to frequently asked questions.

Application Notes: Visit our website <http://www.Ceva-ip.com> or your company's protected page on the Ceva website for the latest application notes.

Email: Use the Ceva central support email address Ceva-support@Ceva-ip.com. Your email will be forwarded automatically to the relevant support engineers and tools developers who will provide you with the most professional support to help you resolve any problem.

License Keys: Refer any license key requests or problems to sdtkeys@Ceva-ip.com. For SDT license keys installation information, see the *SDT Installation and Licensing Scheme Guide*.

Email: ceva-support@Ceva-ip.com

Visit us at: www.ceva-ip.com

Table of Contents

1	INTRODUCTION	1
1.1	Scope.....	1
1.2	Audience	1
1.3	Related Documents	1
1.4	Overview	1
1.5	Feature List.....	1
2	PINOUT	3
3	HOST INTERFACE	5
3.1	Interface Selection	5
3.2	I ² C Interface	5
3.3	UART-RVC Interface	6
3.3.1	UART-RVC Protocol.....	7
3.3.2	RVC Log Mode.....	8
3.4	UART-SHTP Interface	8
3.4.1	UART-SHTP Power Management.....	9
4	CLOCK CONFIGURATION	10
5	SENSORS.....	11
5.1	Overview	11
5.2	LSM6DSR.....	11
5.3	BMI088	11
6	CALIBRATION AND INTERPRETATION.....	13
6.1	Calibration Effects.....	14
6.1.1	Calibration Command	14
6.1.2	Accelerometer.....	14
6.1.3	Gyroscope	14
6.1.4	Calibration Accuracy	15
6.1.5	Recommended Settings.....	15
6.2	Calibration Steps	15
6.3	Persist Dynamic Calibration Data	16
7	COORDINATE SYSTEM	17
8	STARTUP	20
8.1	Timing.....	20
8.2	Messages.....	20
8.2.1	UART-RVC Mode.....	20
8.2.2	UART-SHTP and I ² C Modes	20

10 OPERATION.....	23
10.1 Application Reports and Commands	23
10.2 Bootloader Reports and Commands.....	24
11 FIRMWARE UPGRADE.....	25
11.1 Overview	25
11.2 Messages.....	25
11.2.1 Message Types.....	25
11.2.2 Message Descriptions.....	26
11.3 Procedure	30
11.3.1 Enter Bootloader Mode	30
11.3.2 Enter Device Firmware Upgrade Mode	30
11.3.3 Transfer Device Firmware Image	30
12 CHARACTERISTICS.....	32
12.1 Absolute Maximum Electrical Ratings.....	32
12.2 Recommended Operating Conditions	32
12.3 Electrical Characteristics	32
12.4 Current Consumption	33
12.5 Performance Characteristics	34
12.6 Latency	35
12.7 Simple Calibration.....	36
13 PACKAGING	37
13.1 LQFP48 Package Dimensions	37
13.2 LQFP48 PCB Land Pattern	38
13.3 Marking	39
13.4 Soldering Guidelines	40
13.5 Compliance	40
14 EXAMPLE DESIGN.....	41

List of Figures

Figure 1: I ² C Connection Diagram	6
Figure 2: UART-RVC Connection Diagram	6
Figure 3: FSP201 UART-RVC packet.....	7
Figure 4: Example Packet.....	8
Figure 5: UART-SHTP Connection Diagram	9
Figure 6: UART-SHTP - Sending a message to the FSP201.....	9
Figure 7: LSM6DSR Connection Diagram	11
Figure 8: BMI088 Connection Diagram.....	12
Figure 9: LSM6DSR Orientation and ENU Coordinate System	17
Figure 10: BMI088 Orientation and ENU Coordinate System	17

Figure 11 LSM6DSR Mounted in a Device	18
Figure 12: FSP201 Startup Timing	20
Figure 13: Bootloader SHTTP Advertisement	25
Figure 14: Bootloader Report ID List.....	25
Figure 15: Bootloader Product ID Request	26
Figure 16: Bootloader Product ID Response	26
Figure 17: Bootloader Operating Mode Request.....	27
Figure 18: Bootloader Operating Mode Response.....	27
Figure 19: Bootloader Status Request	27
Figure 20: Bootloader Status Response	28
Figure 21: Bootloader Status Flags	28
Figure 22: Bootloader Error Codes.....	29
Figure 23: Bootloader DFU Write Request.....	29
Figure 24: Bootloader DFU Write Response.....	29
Figure 25: FSP201 Calibration Hardware Example	36
Figure 26 - LQFP48 Package	37
Figure 27 - PCB Land Pattern	38
Figure 28 - Marking	39

List of Tables

Table 1: FSP201 Pinout.....	3
Table 2: Interface Protocol Selection	5
Table 3: Clock Selection	10
Table 4: Accuracy Status of Sensors	15
Table 5: Calibration Procedure for Sensors	16
Table 6 Remapping Quaternion in 90 Deg Rotations	19
Table 7: FSP201 Startup Times	20
Table 8: FSP201 FRS Records	22
Table 9: FSP201 Reports.....	23
Table 10: FSP201 Commands	24
Table 11 - FSP201 Maximum Ratings.....	32
Table 12 - FSP201 Recommend Conditions	32
Table 13: FSP201 Electrical Characteristics.....	33
Table 14: FSP201 Current Consumption	33
Table 15: FSP201 Calibrated Performance Using LSM6DSR.....	34
Table 16: FSP201 Calibrated Performance Using BMI088.....	35
Table 17 Latency.....	36

1 Introduction

1.1 Scope

This document describes the features and operation of the FSP201.

1.2 Audience

This document is intended for software and hardware engineers integrating or using the FSP201.

1.3 Related Documents

The following documents are related to the information in this document:

1. 1000-3535 Sensor Hub Transport Protocol, Ceva, Inc..
2. 1000-3600 SH-2 SHTP Reference Manual, Ceva, Inc..
3. 1000-3625 SH-2 Reference Manual, Ceva, Inc..
4. 1000-5050 Application Note: FSP201 Tare, Ceva, Inc..
5. 1000-4906 Application Note: FSP201 Simple Calibration, Ceva, Inc..
6. 1000-4905 Application Note: FSP20x RVC Data Logging, Ceva, Inc..

1.4 Overview

The FSP201 is a 6-axis IMU processor that provides heading and orientation outputs. When connected to one of several supported sensors, it performs all the accelerometer and gyroscope sensor fusion processing necessary to produce stable and accurate heading and orientation outputs. The FSP201 is suitable for use in robotic products such as consumer floor care products, garden and lawn robots, pool cleaners and follow me and assistant robots used in the hospitality and medical markets. The FSP201 is also suitable for use in wearable motion tracking products such as AR/VR headsets.

1.5 Feature List

The FSP201 offers the following features.

Outputs

- Calibrated acceleration
- Linear acceleration

-
- Gravity
 - Calibrated gyroscope
 - Uncalibrated gyroscope
 - Stability detector
 - Game rotation vector quaternion
 - ARVR Stabilized game rotation vector quaternion with auto-recenter
 - Yaw, pitch, and roll
 - Raw accelerometer
 - Raw gyroscope

Interfaces

- UART-RVC
- UART-SHTP
- UART-RVC-LOG
- I²C

Sensors

- LSM6DSR
- BMI088

Simple calibration

Interactive calibration

The FSP201 interfaces are compatible with Ceva's Hillcrest Labs' BNO08x.

2 Pinout

Table 1: FSP201 Pinout

Pin	Name	Mode	Description/Notes
1	H_SCL	Input	I2C clock, weak internal pullup
2	ACC_INT1	Input	Accelerometer interrupt 1, weak internal pullup
3	VCL	Power	Connect to VSS through 4.7 μ F multilayer ceramic capacitor
4	XCIN	Input	32768 Hz oscillator or pull down to ground
5	XCOU	Output	32768 Hz oscillator or not connected
6	VSS	Power	Ground
7	S_MOSI	Output	Sensor SPI MOSI
8	S_MISO	Input	Sensor SPI MISO, weak internal pullup
9	VCC	Power	Power supply
10	S_SDA	Input	Sensor I2C data, weak internal pullup
11	S_SCL	Input	Sensor I2C clock, weak internal pullup
12	H_SDA	Output	I2C data, weak internal pullup
13	VSS_DCDC	Power	N/C
14	VLO	Power	N/C
15	VCC_DCDC	Power	N/C
16	P208	Reserved	N/C, weak internal pullup
17	CLKSEL0	Input	Clock select 0
18	ACC_INT2	Input	Accelerometer interrupt 2, weak internal pullup
19	H_NRST	Input	Reset. Active low. Connect to VCC using pullup resistor
20	P201/MD	Input	Connect to VCC using pullup resistor
21	P200	Reserved	Connect to VCC using pullup resistor
22	H_SA0	Input	I2C address select
23	Reserved	Output	Reserved, weak internal pullup
24	SWCLK	Debug	Connect to VCC using pullup resistor
25	SWDIO	Debug	Connect to VCC using pullup resistor
26	P109	Reserved	N/C, weak internal pullup
27	Reserved ¹	Input	Reserved
28	Reserved ¹	Input	Reserved
29	S_SCK	Output	Sensor SPI clock
30	VCC	Power	Power supply
31	VSS	Power	Ground
32	H_WAKEN_PS0	Input	Host interface wake, protocol select 0
33	H_PS1	Input	Host interface protocol select 1
34	BOOTN	Input	Bootloader select
35	H_TX_LEDGRN ¹	Output	UART transmit or calibration status
36	H_RX	Input	UART receive, weak internal pullup
37	RVC_LOG	RVC_LOG	RVC log mode, weak internal pullup
38	ROT_INT1	Input	Gyroscope interrupt 1, weak internal pullup

Pin	Name	Mode	Description/Notes
39	ROT_CS_N	Output	Gyroscope SPI chip select
40	H_INTN_LEDRED	Output	Host interface interrupt or calibration status
41	P012	Reserved	N/C, weak internal pullup
42	AVCC0	Power	Power supply
43	AVSS0	Power	Ground
44	P011/VREFL0	Power	Connect to AVSS0
45	P101/VREFH0	Power	Connect to AVCC0
46	CAL_PB	Input	CAL_PB, weak internal pullup
47	ACC_CS_N	Output	Accelerometer SPI chip select
48	ROT_INT2	Input	Gyroscope interrupt 2, weak internal pullup

¹Has weak internal pullup.

3 Host Interface

3.1 Interface Selection

The FSP201 connects to the host microcontroller using one of these serial interfaces:

- I²C
- UART
- UART-RVC (not available in bootloader mode)
- UART-RVC-LOG (not available in bootloader mode)

Interface selection is done at startup time using the protocol select pins – H_PS1 and H_WAKEN_PS0. The settings for the protocol select pins are shown below.

Table 2: Interface Protocol Selection

PS1	PS0	BOOTN=1	BOOTN=0	RVC_LOG
0	0	I ² C	I ² C	x
0	1	UART-RVC	Reserved	1
0	1	UART-RVC_LOG	Reserved	0
1	0	UART	UART	x
1	1	Reserved	Reserved	Reserved

3.2 I²C Interface

The I²C is a standard Fast Mode target interface that operates at up to 400 kb/s. The master device generally drives the clock. However, if the FSP201 device requires additional time to respond it can force the clock low, only releasing the line when it is prepared to deliver more data. The master device MUST support clock stretching. A typical connection diagram is shown in Figure 1.

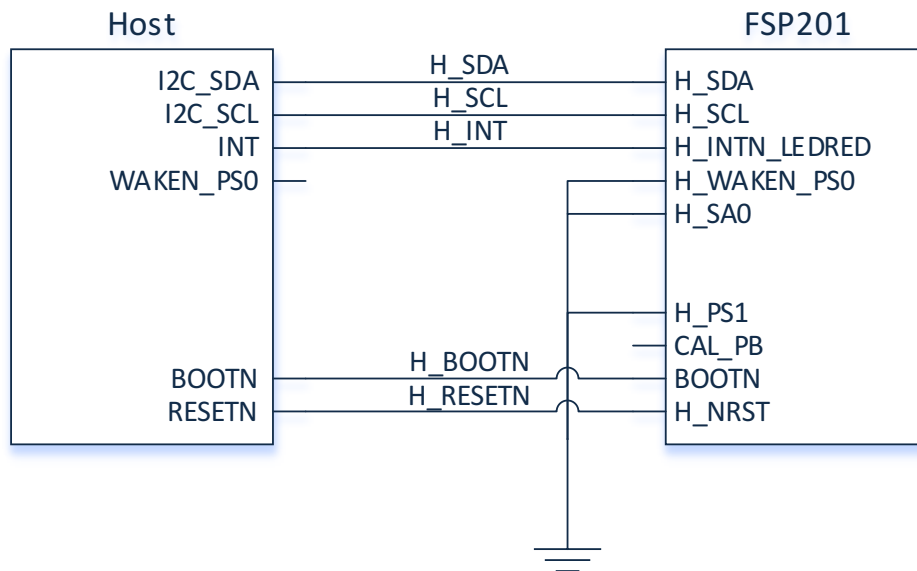

Figure 1: I²C Connection Diagram

The I²C interface uses a 7-bit address of either 0x4C or 0x4D. H_SAO sets the LSB of the address during startup.

3.3 UART-RVC Interface

The UART-RVC interface is a simplified UART interface for use on robot vacuum cleaners (RVC). When configured in this mode the FSP201 transmits heading and sensor information at 100Hz over the UART TX pin. A typical connection diagram is shown in Figure 2.

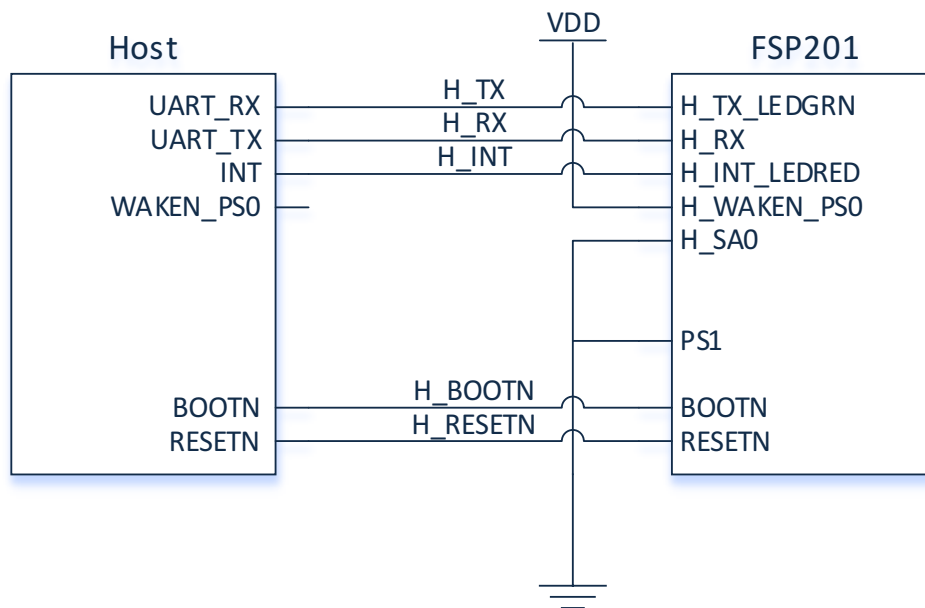

Figure 2: UART-RVC Connection Diagram

The UART-RVC interface operates at 115200 b/s, 8 data bits, 1 stop bit, and no parity.

3.3.1 UART-RVC Protocol

The FSP201 automatically sends data when UART-RVC protocol is selected. The outputs are generated at 100 Hz nominally. The actual output rate depends on the sensor chosen.

3.3.1.1 Format

The format of the packets is shown in Figure 3.

Header	Index	Yaw		Pitch		Roll		X-axis accel		Y-axis accel		Z-axis accel		Interactive Calibration		Rsvd	Csum
0xAAAA		LSB	MSB	LSB	MSB	LSB	MSB	LSB	MSB	LSB	MSB	LSB	MSB	MI	MR	0x00	csum

Figure 3: FSP201 UART-RVC packet

The 19-byte message has the following fields:

Header	Each report is prefixed with a 0xAAAA header
Index	A monotonically increasing 8-bit count is provided (0-255) per report
Yaw	The yaw is a measure of the rotation around the Z-axis since reset. The yaw has a range of +/- 180° and is provided in 0.01° increments, i.e., a report of 8734 is equivalent to 87.34°.
Pitch	The pitch is a measure of the rotation around the X-axis. The pitch has a range of +/- 90° and is provided in 0.01° increments, i.e., a report of 1072 is equivalent to 10.72°.
Roll	The roll is a measure of the rotation around the Y-axis. The roll has a range of +/- 180° and is provided in 0.01° increments, i.e., a report of 1072 is equivalent to 10.72°.
X-axis acceleration	The acceleration along the X-axis, presented in mg
Y-axis acceleration	The acceleration along the Y-axis, presented in mg
Z-axis acceleration	The acceleration along the Z-axis, presented in mg
MI	Motion Intent – this byte reflects the Motion Intent provided to the FSP201. 0 – FME_MOBILE_MOTION_INTENT_UNKNOWN – this is the initial state assumed by the sensor hub 1 – FME_MOBILE_MOTION_INTENT_STATIONARY_WITHOUT_VIBRATION 2 – FME_MOBILE_MOTION_INTENT_STATIONARY_WITH_VIBRATION 3 – FME_MOBILE_MOTION_INTENT_IN_MOTION 4 – FME_MOBILE_MOTION_INTENT_ACCELERATING 5:255 – Reserved
MR	Motion Request – the motion requested by the FSP201. 0 – FME_MOBILE_MOTION_REQUEST_NO_CONSTRAINT. The device may move as desired. 1 – FME_MOBILE_MOTION_REQUEST_STAY_STATIONARY_REQUIRED. The device should remain stationary to refine its calibration to a basic level. 2 – FME_MOBILE_MOTION_REQUEST_STAY_STATIONARY_OPTIONAL. The device should remain stationary to refine its calibration to a high-precision level. If high precision is not required, the device may resume motion. (DEPRECATED. Ignore this request)

	3 – FME_MOBILE_MOTION_REQUEST_NON_URGENT_STATIONARY. The device should stop when convenient to improve its calibration.
	4 – FME_MOBILE_MOTION_REQUEST_URGENT_STATIONARY. The device should stop as soon as possible to improve its calibration.
	5 – FME_MOBILE_MOTION_REQUEST_TIMER_STATIONARY. The device should stop when convenient to check and possibly improve its calibration.
	6:255 – Reserved
Reserved	The message is terminated with one reserved byte, currently set to zero
Checksum (Csum)	The Index, yaw, pitch, roll, acceleration, and reserved data bytes are added to produce the 8-bit checksum.

To determine the actual orientation of the module, the rotations should be applied in the order yaw, pitch then roll.

An example complete message and checksum calculation is as follows:

Header	Index	Yaw		Pitch		Roll		X-axis accel		Y-axis accel		Z-axis accel		Interactive Calibration		Rsvd	Csum
AAAA	DE	01	00	92	FF	25	08	8D	FE	EC	FF	D1	03	00	00	0x00	E7

Figure 4: Example Packet

Where:

Index = 0xDE = 222

Yaw = 00.01° (1 = 0x0001)

Pitch = -1.10° (-110 = 0xFF92)

Roll = 20.85° (2085 = 0x0825)

X-acceleration = -371 mg = -3.638 m/s² (-371 = 0xFE8D)

Y-acceleration = -20 mg = -0.196 m/s² (-20 = 0xFFEC)

Z-acceleration = 977 mg = 9.581 m/s² (977 = 0x03D1)

MI = 0, Motion Intent – unknown

MR = 0, Motion Request – no request

Checksum = 0xE7

3.3.2 RVC Log Mode

The UART-RVC-LOG interface is connected in the same manner as the UART-RVC interface and produces the same data in the same format. In addition, the UART-RVC-LOG interface outputs raw sensor data and other information that may assist with testing or debugging systems. Log mode is enabled by setting RVC_LOG to 0 during startup. See reference [6] for details. Leave RVC_LOG unconnected if it is not used.

3.4 UART-SHTP Interface

The UART-SHTP interface is a high-speed, low latency interface. It operates at a fixed rate of 3 Mbps, 8 data bits, 1 stop bit and no parity. The baud rate is not configurable. A typical connection diagram is shown in Figure 5.

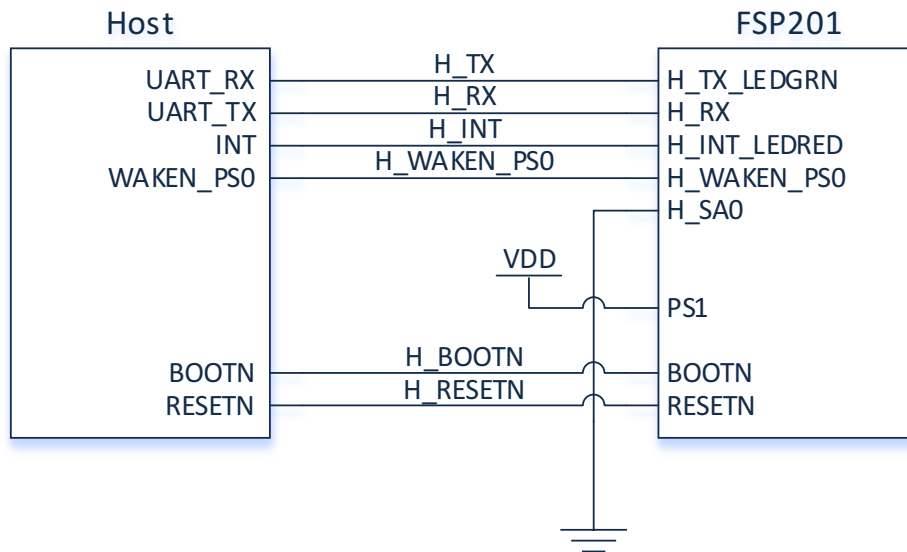

Figure 5: UART-SHTP Connection Diagram

The FSP201 uses the SHTP protocol to communicate. The UART interface uses framing bytes at the beginning and end of transmission. Details are available in reference [1].

3.4.1 UART-SHTP Power Management

When sending data to the FSP201, H_WAKEN_PSO must be asserted low before transmission begins and must be deasserted high after transmission ends. The FSP201 uses the query and notification system described in reference [1]. A BSQ must be sent after H_WAKEN_PSO is asserted low. The FSP201 responds with a BSN. If the FSP201 does not respond with a BSN after 10ms, send the BSQ again. After receiving the BSN, the host may send its message. See Figure 6. Deasserting H_WAKEN_PSO after sending the message allows the FSP201 to enter its lowest power mode.



Figure 6: UART-SHTP - Sending a message to the FSP201

4 Clock Configuration

The FSP201 supports either an external crystal or internal clocking. The accuracy of the crystal should be 50 ppm or better. Use 24 pF tuning capacitors with the crystal. Settings for the CLKSEL0 signal are shown below. An external crystal should be used if the UART interface is used. The internal clock is not accurate enough to operate the UART interface. The XCIN signal should be connected to ground if the internal clock is used.

Table 3: Clock Selection

Source	CLKSEL0
Crystal	0
Internal	1

5 Sensors

5.1 Overview

One accelerometer and one gyroscope must be connected to the FSP201. The supported sensors have both sensor elements in a single package. Connection diagrams for the supported sensors are shown in the following sections.

Sensor specific information is also included in the following sections.

Sensors are connected to the FSP201 using SPI.

5.2 LSM6DSR

The LSM6DSR connection diagram is shown in Figure 7.

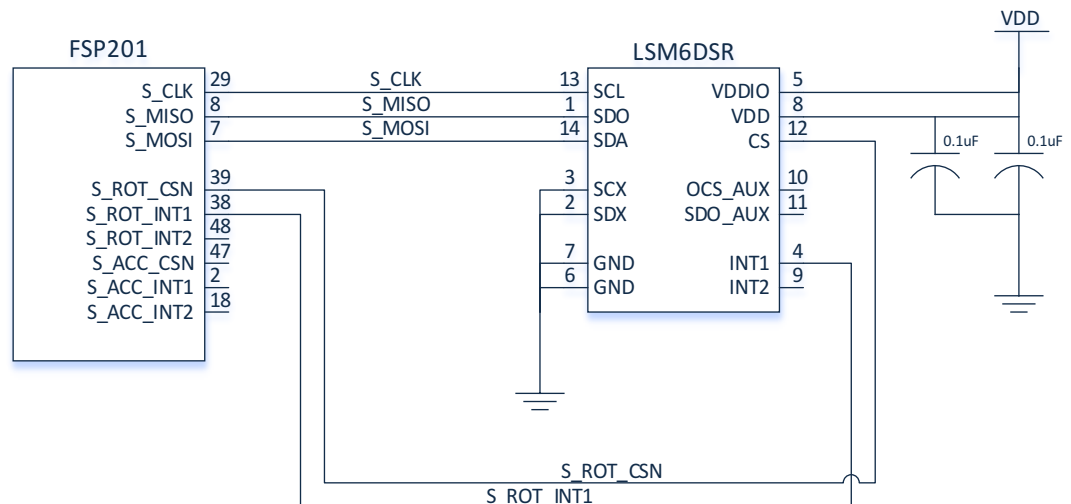

Figure 7: LSM6DSR Connection Diagram

The LSM6DSR is operated at 13 Hz, 26 Hz, 52 Hz, 104 Hz, 208 Hz, or 416 Hz. Operation at frequencies lower than 13 Hz is supported by running the sensor at 13 Hz and reporting only those samples needed to meet the requested frequency.

5.3 BMI088

The BMI088 connection diagram is shown in Figure 8.

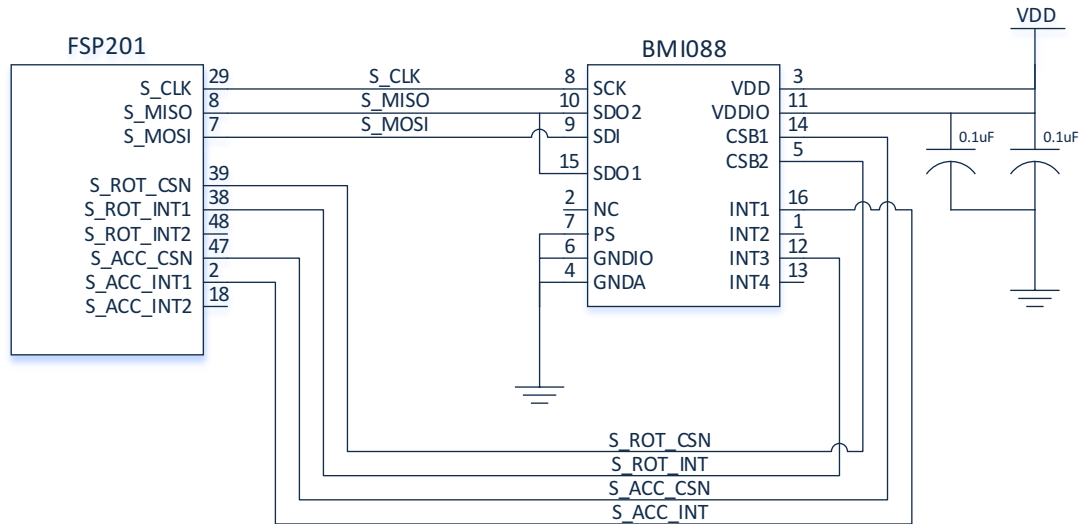

Figure 8: BMI088 Connection Diagram

The BMI088 accelerometer and gyroscope are operated independently of one another. The accelerometer is operated at 12.5 Hz, 25 Hz, 50 Hz, 100 Hz, 200 Hz, 400 Hz, or 800 Hz. The gyroscope is operated at 100 Hz, 200 Hz, 400 Hz, or 1000 Hz. Operation of the gyroscope at frequencies lower than 100 Hz is supported by running the sensor at 100 Hz and reporting only those samples needed to meet the requested frequency.

6 Calibration and Interpretation

The FSP201 interprets the data from its sensors to model the device's motion and ultimately determine the device's orientation and classify the motion of the device. The accuracy of this model is dependent on the quality of the data provided by the sensors.

All sensors exhibit slight imperfections. These imperfections generally appear as errors in offset and scale. Sensor systems that contain three axes have an additional variant of offset that includes skew and rotation (skew is the non-orthogonality of the three axes and rotation is the angular difference of the coordinate frame of the sensor to the coordinate frame of the device). Calibration of the sensor data falls into two categories:

- Static calibration
- Dynamic calibration

Static calibration is the correction of non-varying parameters to the data returned from the sensors. These static adjustments to the data typically compensate for offsets and scaling errors that do not vary over time or with temperature. Examples (this list is not exhaustive) of non-varying errors (or errors that are not compensated for dynamically) are:

- Accelerometer or gyroscope skew (also called cross-axis sensitivity)
- Accelerometer or gyroscope gain or sensitivity
- Sensor orientation with respect to device frame of reference

A static calibration data record (SCD) is essentially a description of the sensor system used on the device and from that record the FSP201 calibrates and interprets the data from the sensors producing data in the appropriate SI units for use by applications. The SCD record can be generic and essentially describe the sensors as per the datasheet, or the record can be specific to the actual sensors in the package.

Dynamic calibration is the correction to the data returned from the sensors that varies with either time or temperature. The FSP201 calculates what the adjustment should be during use of the sensor and applies correction factors as necessary in real time. Examples of dynamic calibration parameters are:

- Gyroscope zero-rate offset
- Accelerometer zero-g offset

In addition, as the FSP201 has applications in devices such as Robot Vacuum Cleaners it is necessary to calibrate the accelerometer in a planar fashion (i.e. around the axis that the vacuum cleaner revolves). Selection of 3D or planar accelerometer calibration is via a command from the host.

6.1 Calibration Effects

This section provides a brief overview of the benefits of dynamic calibration and the recommended settings for various applications.

6.1.1 Calibration Command

The SH-2 firmware in the FSP201 allows a host microcontroller to enable or disable the dynamic calibration of the accelerometer, gyroscope. Refer to the SH-2 Reference Manual [3] for the command used to control calibration of each sensor. The command allows the host to control when calibration is performed. Note that the calibration settings do not persist across resets of the FSP201.

6.1.2 Accelerometer

Dynamic calibration for an accelerometer is the removal of zero-g offset (ZGO). An accelerometer at rest should only report gravity, any deviation is the zero-g offset. This is most easily seen when the accelerometer is placed with one axis perpendicular to the Earth, the other two axes should report zero. ZGO errors can manifest as tilts or tilt corrections (e.g., the screen on a head mounted display may be tilted with respect to the expected horizon) and this usually indicates that the accelerometer needs to be calibrated. The FSP201 provides two methods of calibrating the accelerometer ZGO; a full 3-dimensional approach for devices that can move in freely in space and a planar calibration for devices that are constrained to move in a plane (such as a robot vacuum cleaner). For more information on calibrating the accelerometer, see section 6.2.

6.1.3 Gyroscope

Dynamic calibration for a gyroscope is the removal of zero rate offset (ZRO). A gyroscope at rest should report zero rad/s on all axes. Any deviation from zero is the zero-rate offset (ZRO). ZRO errors can manifest as drifts (e.g., the screen on a head mounted display can continue moving even when the device is stationary). Note that though the FSP201 can continuously attempt to calibrate the gyroscope for ZRO, it is possible to fool the calibration algorithms through slow horizontal rotations (around the gravity vector).

The FSP201 has two algorithms for dynamic calibration: on-table and in-hand. On-table calibration is enabled by default and should be used for ground-based robots.

In-hand calibration should be used for devices that are worn and must be enabled by a command message. Placing the device on a stable surface will force the ZRO calibration to converge rapidly. The gyroscope in-hand calibration algorithm attempts to remove ZRO while the device is not on a very stable surface. For this to be successful the device to which the FSP201 is mounted must have sufficient tremor such as the human hand. If there is insufficient tremor it is advisable to disable the gyroscope calibration to prevent drift (i.e., by mis-calibrating ZRO). ZRO will always be corrected when the device becomes very stable (such as when laid on a table).

6.1.4 Calibration Accuracy

The FSP201 provides input reports to send sensor data to the host microcontroller. The calibrated input reports include a “Status” field that indicates the accuracy status of the sensor. This is especially useful when the application needs to know the calibration status of the FSP201 outputs. Bits 1:0 of the Status field indicate the accuracy as shown in Table 4. Refer to the SH-2 Reference Manual [3] for more information.

Table 4: Accuracy Status of Sensors

Status Bits (1:0)	Description
0	Unreliable
1	Accuracy Low
2	Accuracy Medium
3	Accuracy High

6.1.5 Recommended Settings

The planar accelerometer calibration and on-table gyroscope calibration are enabled by default. These settings are suitable for ground-based robots. For applications in which the FSP201 is worn, 3D accelerometer and in-hand gyroscope calibrations should be enabled. However, the user should verify performance with their specific motion profile.

6.2 Calibration Steps

For best motion tracking performance, it is recommended to statically calibrate the FSP201. Since each MEMS sensor part has different individual characteristics, each device using the FSP201 may be statically calibrated individually. For more details on the procedure to calibrate the FSP201, refer to the FSP201 Simple Calibration application note [5].

In normal use the FSP201 will be exposed to conditions that will allow dynamic calibration to occur with no explicit user input. The steps below may be followed to force a dynamic calibration.

Table 5: Calibration Procedure for Sensors

Sensor	Calibration Procedure
Accelerometer	For 3D calibration the device should be moved into 4-6 unique orientations and held in each orientation for about 1 second to calibrate the accelerometer. For planar calibration, the device should be rotated between two stationary points around its Z-axis by 180 degrees
Gyroscope	Device should be set down on a stationary surface for approximately 2-3 seconds to calibrate the gyroscope

6.3 Persist Dynamic Calibration Data

The FSP201 stores updated Dynamic Calibration Data (DCD) to RAM frequently (every 5 seconds). At non-power-up reset, the FSP201 will persist the last-stored DCD from RAM to FRS. To clear the DCD from RAM before system reset, use the Clear-DCD and Reset command [3].

For SHTP interface, the last stored DCD can be saved to FRS during operation through specific commands; the Save DCD request and the Configure Periodic DCD Save command. More details are available in [3].

7 Coordinate System

The coordinate system for the FSP201 is determined by the placement and orientation of the connected sensor. The default orientations are shown below. All views are top views with the Z-axis pointing up. The default coordinate system is East/North/Up (ENU).

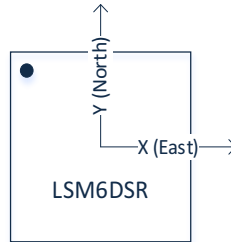

Figure 9: LSM6DSR Orientation and ENU Coordinate System

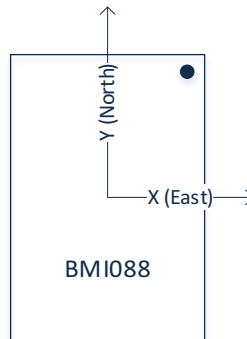

Figure 10: BMI088 Orientation and ENU Coordinate System

If the sensor must be installed in an orientation different from the desired coordinate system, the system orientation record (record ID 0x2D3E) can be modified to align the coordinate system as desired. See reference [3] for details of updating the system orientation record.

For example, if the LSM6DSR is mounted such that its positive Y-axis was aligned opposite to the X-axis of the device it was mounted in, but with its Z-axis aligned correctly, a clockwise rotation of 90° around the Z-axis would be required.

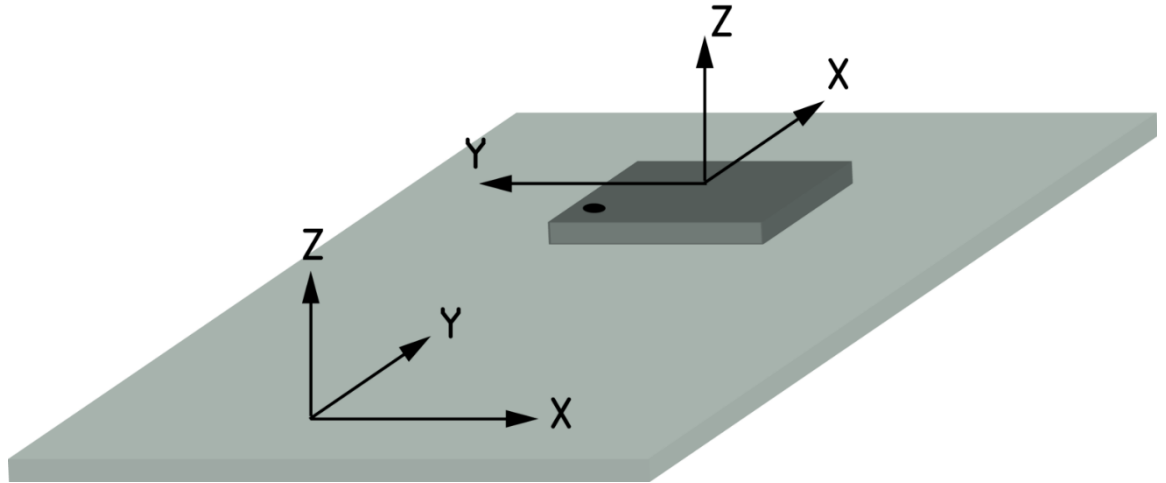

Figure 11 LSM6DSR Mounted in a Device

This rotation would be represented by a quaternion of $(\frac{\sqrt{2}}{2}, 0, 0, \frac{\sqrt{2}}{2})$.

Assume that for the LSM6DSR is mounted in, the Z-axis is Up, the X-axis is East, and the Y-axis is North. Examples of mappings for LSM6DSR mounting are provided below to clarify the use of the FRS record:

The highlighted row is also shown pictorially in Figure 11. For rotations that are not a multiple of 90-degree rotations the appropriate angular rotations should be applied.

Table 6 Remapping Quaternion in 90 Deg Rotations

LS6DSR physical axis aligned			Mapping quaternion			
X	Y	Z	Qw	Qx	Qy	Qz
East	North	Up	1	0	0	0
North	West	Up	$(\sqrt{2})/2$	0	0	$(\sqrt{2})/2$
West	South	Up	0	0	0	1
South	East	Up	$(\sqrt{2})/2$	0	0	$-(\sqrt{2})/2$
East	South	Down	0	0	-1	0
North	East	Down	0	$-(\sqrt{2})/2$	$-(\sqrt{2})/2$	0
West	North	Down	0	-1	0	0
South	West	Down	0	$-(\sqrt{2})/2$	$(\sqrt{2})/2$	0
Up	South	East	0	0	$-(\sqrt{2})/2$	$(\sqrt{2})/2$
North	Up	East	1/2	-1/2	-1/2	1/2
Down	North	East	$(\sqrt{2})/2$	$-(\sqrt{2})/2$	0	0
South	Down	East	1/2	-1/2	1/2	-1/2
Up	North	West	$-(\sqrt{2})/2$	$-(\sqrt{2})/2$	0	0
North	Down	West	-1/2	-1/2	-1/2	-1/2
Down	South	West	0	0	$-(\sqrt{2})/2$	$-(\sqrt{2})/2$
South	Up	West	1/2	1/2	-1/2	-1/2
Up	East	North	-1/2	-1/2	-1/2	1/2
West	Up	North	0	$-(\sqrt{2})/2$	0	$(\sqrt{2})/2$
Down	West	North	1/2	-1/2	1/2	1/2
East	Down	North	$-(\sqrt{2})/2$	0	$-(\sqrt{2})/2$	0
Up	West	South	1/2	1/2	-1/2	1/2
West	Down	South	0	$-(\sqrt{2})/2$	0	$-(\sqrt{2})/2$
Down	East	South	1/2	-1/2	-1/2	-1/2
East	Up	South	$(\sqrt{2})/2$	0	$-(\sqrt{2})/2$	0

8 Startup

8.1 Timing

Startup timing for the FSP201 is shown in Figure 12.

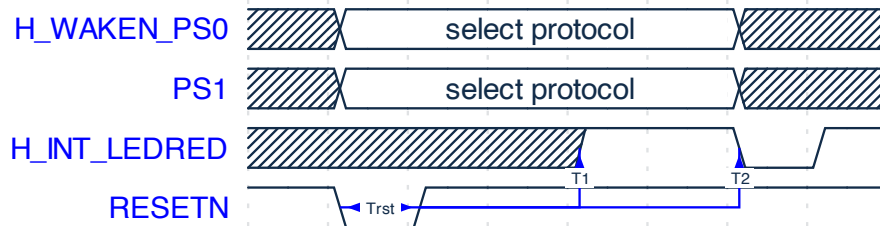

Figure 12: FSP201 Startup Timing

Table 7: FSP201 Startup Times

Symbol	Description	Min	Typ	Max
Trst	Reset pulse at power on	10 ms	-	-
Trst	Reset pulse other than at power on	30 μ S	-	-
T1	Time for processor initial configuration	-	153 ms	-
T2	Time until processor fully running (LSM6DSR)	-	857 ms	-
T2	Time until processor fully running (BMI088)	-	871 ms	-

8.2 Messages

8.2.1 UART-RVC Mode

When the FSP201 is configured for UART-RVC mode it starts up and sends a string resembling the following:

```
%Ceva, Inc. 10004 818
```

```
%SW Ver 3.12.x
```

```
%(c) 2017 Hillcrest Laboratories, Inc.
```

This message informs the user that the FSP201 has exited reset and provides version information.

Following this message, the FSP201 issues data packets according to section 3.3.1.

8.2.2 UART-SHTP and I²C Modes

The FSP201 starts up with all sensors disabled, waiting for the application processor to configure it.

8.2.2.1 Establishing Contact

After power up or reset the FSP201 asserts the interrupt (HOST_INTN) indicating that the reset routine has completed and that the FSP201 is ready for communication. The FSP201 sends the initial SHTP advertisement packet. This packet details the SHTP channel assignments and packet length parameters (see [1], [2], and [3]). Following the SHTP advertisement packet, the individual applications built into the FSP201 will send a packet indicating they have left the reset state:

The executable will issue a reset message on SHTP channel 1.

SH-2 will issue an unsolicited initialization message on SHTP channel 2.

Beyond these initial messages the FSP201 waits for configuration by the host.

9 Configuration

The FSP201 stores configuration parameters in flash. It uses SH-2 records and FRS read and write messages. See [3] for details of the messages and records. Table 8 lists the records used by the FSP201.

Table 8: FSP201 FRS Records

Record ID	Description
0x7979	Static calibration – AGM
0x4D4D	Nominal calibration – AGM
0x1F1F	Dynamic calibration
0xD3E2	MotionEngine power management
0x2D3E	System orientation
0x2D41	Primary accelerometer orientation
0x2D46	Gyroscope orientation
0xD7D7	Maximum fusion period
0x4B4B	Serial number
0x74B4	User record
0xD403	MotionEngine Time Source Selection
0xA1A4	Simple Calibration Configuration
0xA1A5	Nominal Simple Calibration Configuration
0xA1A1	UART-RVC output format selection
0x3E2E	ARVR GRV Stabilization
0x3ECE	ARVR GRV Centering

10 Operation

When using the UART-SHTP host interface, operation of the FSP201 can be controlled by the host. The FSP201 follows the report and command definitions defined in [3]. The FSP201 supports a subset of those reports and commands while defining several new reports and commands of its own. In some cases, various fields in existing reports may not be used. These variations from [3] are explained in the following sections.

10.1 Application Reports and Commands

Table 9 lists the reports used by the FSP201.

Table 9: FSP201 Reports

SHTP Channel	Direction	Report ID	Description
SH-2 Control	W	0xFE	Get Feature Request
SH-2 Control	W	0xFD	Set Feature Command
SH-2 Control	R	0xFC	Get Feature Response
Normal	R	0xFB	Base Timestamp Reference
SH-2 Control	W	0xF9	Product ID Request
SH-2 Control	R	0xF8	Product ID Response
SH-2 Control	W	0xF7	FRS Write Request
SH-2 Control	W	0xF6	FRS Write Data
SH-2 Control	R	0xF5	FRS Write Response
SH-2 Control	W	0xF4	FRS Read Request
SH-2 Control	R	0xF3	FRS Read Response
SH-2 Control	W	0xF2	Command Request
SH-2 Control	R	0xF1	Command Response
Normal	R	0x01	Accelerometer
Normal	R	0x02	Gyroscope
Normal	R	0x04	Linear Acceleration
Normal	R	0x06	Gravity
Normal	R	0x07	Uncalibrated Gyroscope
Normal	R	0x08	Game Rotation Vector
Normal	R	0x14	Raw Accelerometer
Normal	R	0x15	Raw Gyroscope
Normal	R	0x2B	Motion Request

The batch interval field in set feature command and get feature response is not used by the FSP201. In the set feature command, this field should be set to zero. In the set feature response, the FSP201 sets this field to zero.

Although the FSP201 does not support batching, the base timestamp reference report is still used. Using this report allows the timestamp interpretation for the FSP201 and other products using the SH-2 reports to be done identically. Table 10 lists the commands used by the FSP201.

Table 10: FSP201 Commands

Id	Name	Description
1	Errors	Command and Response to access error queue.
2	Counter	Command and Response to access counters.
3	Tare	Command and Response to operate on tare
4	Initialize	Reinitialize sensor hub components.
6	DCD	Command to save DCD.
7	ME CAL	Command and Response to configure ME Calibration.
8	Reserved	Deprecated.
9	DCD Save	Command to configure periodic saving of DCD.
10	Oscillator	Command to retrieve the oscillator type used in the clock system.
11	Clear DCD and Reset	Command to clear the in-memory DCD state and perform a chip reset.
12	Simple Cal	Command to control the simple calibration process.
14	Interactive Cal	Command to control interactive calibration.

For the Tare command, only tare now for the game rotation vector is supported.

10.2 Bootloader Reports and Commands

Commands for retrieving bootloader status and issuing bootloader commands from the application are documented in section 11.

11 Firmware Upgrade

11.1 Overview

The FSP201 supports in-field firmware upgrades. Upgrades are performed by placing the FSP201 in bootloader mode and then performing a DFU operation. The FSP201 may be placed in bootloader mode by holding BOOTN low during reset or by issuing a “Reset to Bootloader” message, described below. When in bootloader mode, the FSP201 uses SHTP to communicate with the host. The SHTP advertisement for the bootloader is listed in Figure 13. The bootloader uses only one channel, control, for communications.

Tag	Tag Name	Value
1	GUID	10
8	AppName	Bootloader
6	NormalChannel	1
9	ChannelName	control

Figure 13: Bootloader SHTP Advertisement

11.2 Messages

The messages used to communicate with the bootloader are described below. Some messages may also be used with the SH-2 application to get information about the bootloader or trigger a bootloader operation.

11.2.1 Message Types

The bootloader message types are listed below. All messages are supported by the bootloader. A subset of these messages is supported by the application.

Application Channel	Bootloader Channel	Direction	Report ID	Description
SH-2 Control	Bootloader Control	W	0xE1	Bootloader Product ID Request
SH-2 Control	Bootloader Control	R	0xE2	Bootloader Product ID Response
SH-2 Control	Bootloader Control	W	0xE3	Bootloader Operating Mode Request
	Bootloader Control	R	0xE4	Bootloader Operating Mode Response
SH-2 Control	Bootloader Control	W	0xE5	Bootloader Status Request
SH-2 Control	Bootloader Control	R	0xE6	Bootloader Status Response
	Bootloader Control	W	0xE7	Bootloader DFU Write Request
	Bootloader Control	R	0xE8	Bootloader DFU Write Response

Figure 14: Bootloader Report ID List

11.2.2 Message Descriptions

11.2.2.1 Bootloader Product ID Request

The bootloader product ID request is used to request product ID information from the FSP201 bootloader.

Byte	Description
0	Report ID = 0xE1
1	Reserved

Figure 15: Bootloader Product ID Request

11.2.2.2 Bootloader Product ID Response

The bootloader product ID response returns product ID information about the FSP201 bootloader.

Byte	Description
0	Report ID = 0xE2
1	Reserved
2	Reserved
3	Reserved
4	SW Part Number LSB
5	SW Part Number ...
6	SW Part Number ...
7	SW Part Number MSB
8	SW Version Patch LSB
9	SW Version Patch MSB
10	SW Version Minor
11	SW Version Major
12	SW Build Number LSB
13	SW Build Number ...
14	SW Build Number ...
15	SW Build Number MSB

Figure 16: Bootloader Product ID Response

SW Part Number: 32-bit value representing the software part number
SW Version: software version major (8 bits). minor (8 bits). patch (16 bits)
SW Build Number: 32-bit software build number

11.2.2.3 Bootloader Operating Mode Request

The bootloader operating mode request is used to request various operating modes of the FSP201 bootloader.

Byte	Description
0	Report ID = 0xE3
1	Bootloader Operating Mode ID

Figure 17: Bootloader Operating Mode Request

Operating Mode ID:

- 0 – Reset to bootloader Mode
- 1 – Upgrade Application Mode; upgrade the application image in flash.
- 2 – Validate Image Mode; validate an application image without updating the flash
- 3 – Launch Application; launch the application image in flash.

11.2.2.4 Bootloader Operating Mode Response

The bootloader operating mode response reports the ID and the result of the operating mode last requested.

Byte	Description
0	Report ID = 0xE4
1	Bootloader Operating Mode ID
2	Status (0 – success, 1 – error)
3	Reserved

Figure 18: Bootloader Operating Mode Response

11.2.2.5 Bootloader Status Request

The bootloader status request is used to acquire the status of the FSP201 bootloader.

Byte	Description
0	Report ID = 0xE5
1	Reserved

Figure 19: Bootloader Status Request

11.2.2.6 Bootloader Status Response

The bootloader status response reports the status of the bootloader. The application and the bootloader would send status response messages in response to status request messages. The bootloader would also send status responses to the host when errors occurred.

The bootloader operating mode ID field shows the operating mode last requested, while the status code reports the status and the result of the current bootloader operation.

Byte	Description
0	Report ID = 0xE6
1	Bootloader Operating Mode ID (Section 8.2.2.3)
2	Reserved
3	Reserved
4	Bootloader Status LSB (Figure 21)
5	Bootloader Status ...
6	Bootloader Status ...

Byte	Description
7	Bootloader Status MSB
8	Bootloader Error Codes LSB (Figure 22)
9	Bootloader Error Codes ...
10	Bootloader Error Codes ...
11	Bootloader Error Codes MSB

Figure 20: Bootloader Status Response

Bitmask	Status Code
0x00000000	No status update
0x00000001	Launch application
0x00000002	Launch bootloader
0x00000004	Upgrade operation started
0x00000008	Validate operation started
0x00000010	Internal application valid
0x00000020	Internal application invalid
0x00000040	DFU image valid
0x00000080	DFU image invalid
0x40000000	Error occurred. Refer to Error Code field for details.
0x80000000	Source of DFU status. 1 – Bootloader; 0 - Application

Figure 21: Bootloader Status Flags

Value	Error
0x00	No error
0x01	Unexpected command received
0x02	Invalid internal application
0x03	Flash erase error
0x04	Flash write error
0x05	Flash lock error
0x06	Flash overflow
0x07	Invalid DFU image type
0x08	Invalid DFU image size
0x09	Invalid DFU image version
0x0A	Incompatible hardware
0x0B	Reserved
0x0C	Reserved
0x0D	DFU image length mismatch
0x0E	Invalid application size in DFU image
0x0F	Invalid application CRC in DFU image
0x10	Invalid DFU image CRC
0x11	Invalid data payload length in request message
0x12	Invalid data offset in request message

Figure 22: Bootloader Error Codes

11.2.2.7 Bootloader DFU Write Request

The bootloader DFU write request is used to send the payload of the DFU image to the bootloader.

Byte	Description
0	Report ID = 0xE7
1	Length
2	Word Offset LSB
3	Word Offset MSB
4	Data0 LSB
5	Data0 ...
6	Data0 ...
7	Data0 MSB
8
N-3	Data# LSB
N-2	Data# ...
N-1	Data# ...
N	Data# MSB

Figure 23: Bootloader DFU Write Request

Length: Length of the DFU image payload in words. The maximum size of the payload is 16 words.

Word Offset: Offset, in 32-bit words, from the beginning of the DFU image indicating where in the file the data is to be written

Data#: 32-bit words of DFU image

11.2.2.8 Bootloader DFU Write Response

The bootloader DFU write response reports the status of the DFU write request.

Byte	Description
0	Report ID = 0xE8
1	Status (0 – success, 1 – error)
2	Word Offset LSB
3	Word Offset MSB

Figure 24: Bootloader DFU Write Response

11.3 Procedure

11.3.1 Enter Bootloader Mode

There are two ways to place the FSP201 in bootloader mode: hold the BOOTN signal low during system reset or issue a “Reset to Bootloader” operating mode request followed by a system reset. A bootloader status response message is sent shortly after startup to report the status of the device. The source bit in the status field of the status response message should be set to indicate that the device is running the bootloader.

11.3.2 Enter Device Firmware Upgrade Mode

11.3.2.1 Entering from Bootloader Mode

The FSP201 may be placed in upgrade application mode from bootloader mode by issuing an “Upgrade” operating mode request. The device issues an operating mode response to acknowledge the request. Once the device has switched to device firmware upgrade mode, a status response message is sent to report the status of the device.

11.3.2.2 Entering from Application Mode

The FSP201 may switch from the application to any one of the bootloader operating modes directly without explicitly switching to the bootloader first. The host application can issue an operating mode request to the application. The request is stored in RAM and processed during the next system reset.

11.3.3 Transfer Device Firmware Image

Device firmware image is transferred to the device in chunks through a sequence of Bootloader DFU write requests. The maximum size of firmware image payload for each request is 16 words.

After the device is placed in device firmware upgrade mode, the host software sends the device firmware image through DFU write requests. The bootloader issues a DFU write response message, reporting any errors, immediately after processing each DFU write request. Any DFU write request received before the bootloader responds to the previous write request is dropped.

When the end of the device firmware image is detected, the bootloader validates the newly programmed application image in flash and reports the status through a bootloader status response message.

If any error occurs while processing the device firmware image, the bootloader terminates the firmware upgrade process and notifies the host with a status response message. Any further write requests are ignored.

The host may use the operating mode request to reset/switch the bootloader operating mode after the upgrade process is complete or terminated.

12 Characteristics

12.1 Absolute Maximum Electrical Ratings

Table 11 - FSP201 Maximum Ratings

Parameter	Symbol	Value	Unit
Power supply voltage	VCC, AVCC0	-0.3 to 6.5	V
Input voltage	V _{in}	-0.3 to VCC – 0.3	V
Storage temperature	T _{stg}	-55 to 125	°C

12.2 Recommended Operating Conditions

Table 12 - FSP201 Recommend Conditions

Parameter	Symbol	Min	Typ	Max	Unit
Power supply voltage	VCC, AVCC0	1.6	-	5.5	V
Input voltage	V _{IL}	-	-	0.5	V
Input voltage	V _{IH}	2.2	-	-	V
Operating temperature	T _{oper}	-	-	-40 to 85	°C

12.3 Electrical Characteristics

The electrical characteristics of the FSP201 are listed below.

Table 13: FSP201 Electrical Characteristics

Parameter	Symbol	Conditions	Min	Typ	Max	Unit
Input high voltage	V_{IH}		$0.8 * VCC$	-	-	V
Input low voltage	V_{IL}		-	-	$0.2 * VCC$	V
Output high voltage	V_{OH}	$VCC \geq 2.7 V, I_{OH}=4 mA$ $VCC < 2.7 V, I_{OH}=0.5 mA$	$VCC - 0.8$ $VCC - 0.5$	-	-	V
Output low voltage	V_{OL}	$VCC \geq 2.7 V, I_{OL}=8 mA$ $VCC < 2.7 V, I_{OL}=0.6 mA$	-	-	0.8 0.4	V
POR Voltage threshold on VCC falling	V_{PDR}	VCC falling	-	1.50	-	V
POR Voltage threshold on VCC rising	V_{POR}	VCC rising	-	1.51	-	V
Input leakage current	I_{LEAK}		-	-	1	μA
CAL_PB asserted	t_{LOW}		50	-	-	nS
Crystal frequency	f_{LFXO}		-	32768	-	Hz
Crystal ESR	ESR_{LFXO}		-	-	70	k Ω
Crystal start-up time	t_{LFXO}		-	500	-	ms

12.4 Current Consumption

The current consumption of the FSP201 is dependent on the configuration of the device including the sample rates of various sensors. Table 14 provides typical current consumption numbers for I²C and UART configurations. Measurements were taken with VCC at 3.0VDC. The clock source is an external crystal. The sensor was an LSM6DSR. The sensor's current is not included below but the sensor determines the actual operating rate of the system.

Table 14: FSP201 Current Consumption

Function	Sensor Rate (Hz)	I ² C (mA)	UART (mA)
Idle Power	—	0.163	0.002
UART-RVC mode	104	—	3.20
Game Rotation vector	104	1.23	0.90
Game Rotation vector	416	4.29	3.46
Accelerometer	104	0.65	0.34
Accelerometer	416	2.10	1.34
Gyroscope	104	0.96	0.65
Gyroscope	416	3.21	2.44

12.5 Performance Characteristics

The performance of the LSM6DSR is shown in Table 15. For optimum performance, the gyroscope Z-axis must be calibrated for scale using simple calibration. See section 12.7.

Table 15: FSP201 Calibrated Performance Using LSM6DSR

Parameter	Performance Metric	Typical
Roll/Yaw	Resolution	0.01°
	Range	± 180°
Pitch	Resolution	0.01°
	Range	± 90°
Accelerometer	Range	± 8g
	Resolution	0.244 mg (16-bit)
	Noise density	60 µg/√Hz
	Scale error	1%
	Zero-g offset initial	40 mg
	Zero-g offset after dynamic calibration	20 mg
Gyroscope	Range	± 2000 °/s
	Resolution	0.07 °/s (16-bit)
	Noise density	0.007 °/s/√Hz
	Scale error @25°C uncalibrated	1%
	Z-axis scale error calibrated	0.2%
	Scale error over temperature	0.007 %/°C
	Offset after dynamic calibration	0.007 °/s
Startup time – RVC mode	UART reports from reset	968 ms
Composite Sensor	Performance Metric	Typical
Gaming Rotation Vector	Non-heading Error - dynamic	2.5°
	Non-heading Error - static	1.0°
	Heading Drift - dynamic	0.3°/min ¹
		0.8°/min ²
Gravity	Angle Error - static	1.0°
Linear Acceleration	Accuracy - dynamic	0.35 m/s ²

¹ After operation over a typical temperature range and using interactive calibration.

² After operation over a typical temperature range.

The performance of the FSP201 using the BMI088 sensor is as shown in Table 16. For optimum performance, the gyroscope Z-axis must be calibrated for scale using simple calibration. See section 12.7.

Table 16: FSP201 Calibrated Performance Using BMI088

Parameter	Performance Metric	Typical
Roll/Yaw	Resolution	0.01°
	Range	± 180°
Pitch	Resolution	0.01°
	Range	± 90°
Accelerometer	Range	± 6g
	Resolution	0.18 mg (16-bit)
	Noise density	190 µg/√Hz (Z-axis), 160 µg/√Hz (X and Y axis)
	Scale error	1%
	Zero-g offset initial	20 mg
	Zero-g offset after dynamic calibration	20 mg
Gyroscope	Range	± 2000 °/s
	Resolution	0.06 °/s (16-bit)
	Noise density	0.014 °/s/√Hz
	Scale error @25°C uncalibrated	1%
	Z-axis scale error calibrated	0.3%
	Scale error over aging	0.7%
	Scale error over temperature	0.03 %/°C
	Offset after dynamic calibration	0.006 °/s
Startup time – RVC mode	UART reports from reset	900ms
Composite Sensor	Performance Metric	Typical
Gaming Rotation Vector	Non-heading Error - dynamic	2.5°
	Non-heading Error - static	1.0°
	Heading Drift – dynamic	0.17°/min ¹
		0.5°/min ²
Gravity	Angle Error - static	1.0°
Linear Acceleration	Accuracy - dynamic	0.35 m/s ²

¹ After operation over a typical temperature range and using interactive calibration.

² After operation over a typical temperature range.

12.6 Latency

Latency is a measure of the response of the FSP201 to motion and is typically reserved for continuous sensors. The time to generate an output can be divided into several parameters:

- Sensor delay
- Processing delay
- Algorithmic delay
- Communication delay

The sensors will generate an output reflecting motion within the sample period just measured. The sensor interrupt is assumed to be the end of the sample. The processing time of the FSP201 is dependent on the output of interest. The output for fused sensors follows a gyroscope sample and requires additional processing to fuse the gyroscope data with the accelerometer. Processing time is measured from data becoming available from the sensor to data being made available to the host (H_INTN asserted). The communication delay is dependent upon the transfer speed of the communication medium chosen, and the host's ability to respond to interrupts and support the maximum clock rate of the FSP201. The measured latency from the start of motion to the completion of report transmission for the FSP201 is provided in Table 17.

Table 17 Latency

Sample Rate and Interface	BMI088	LSM6DSR
100 Hz - RVC	18 ms	25 ms
100 Hz - I2C	13 ms	21 ms
100 Hz - SHTP UART	12 ms	20 ms
200 Hz - I2C	8 ms	6 ms
200 Hz - SHTP UART	7 ms	6 ms
400 Hz - I2C	10 ms	4 ms
400 Hz - SHTP UART	10 ms	4 ms

12.7 Simple Calibration

The FSP201 has a special mode, called simple calibration, allowing for Z-axis calibration. This mode may be entered via SHTP commands, or it may be entered using the CAL_PB input signal. The progress and status of the calibration are reported via SHTP commands and the H_TX_LEDGRN and H_INT_LEDRED signals. See [5] for details.

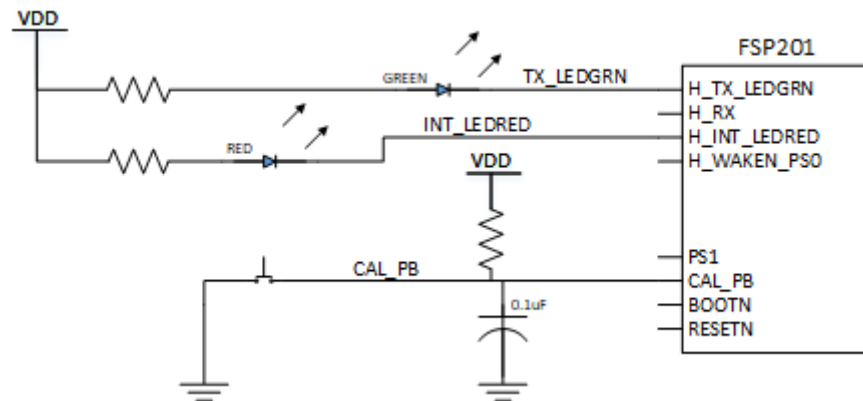

Figure 25: FSP201 Calibration Hardware Example

13 Packaging

13.1 LQFP48 Package Dimensions

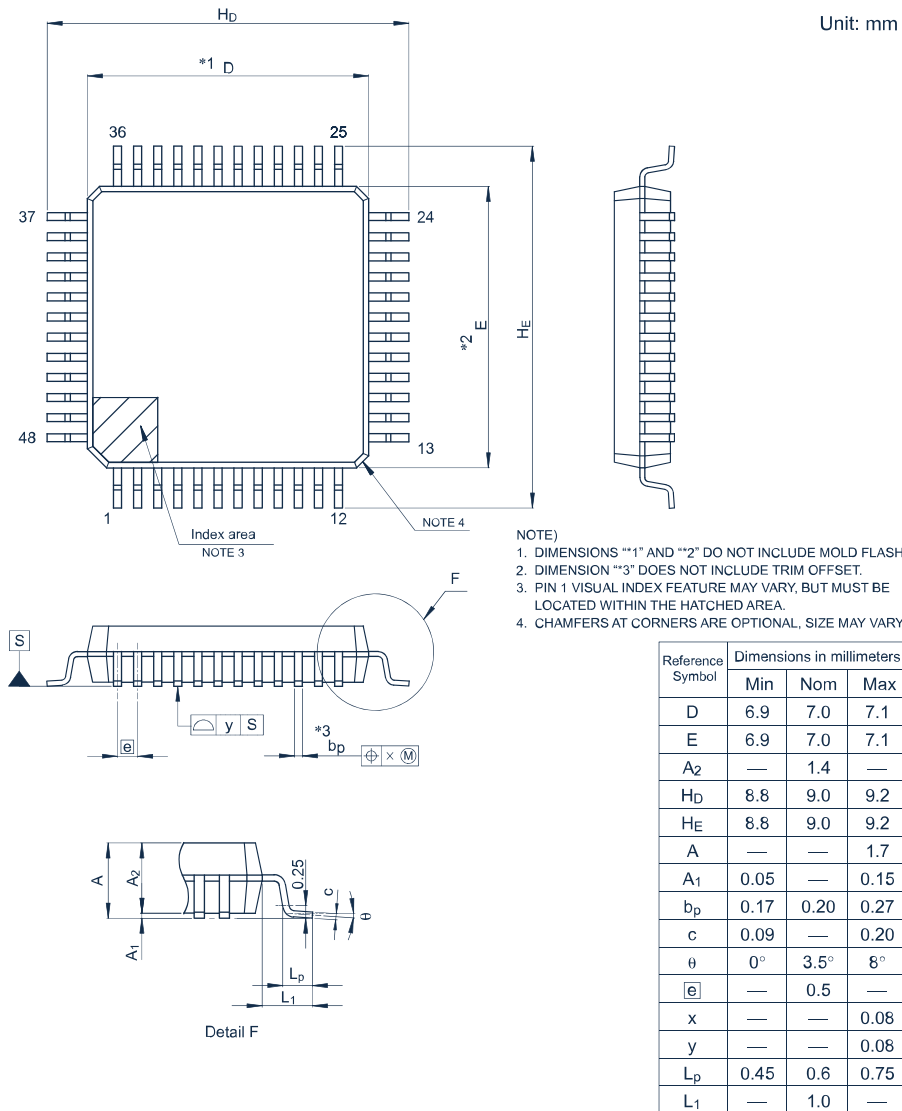
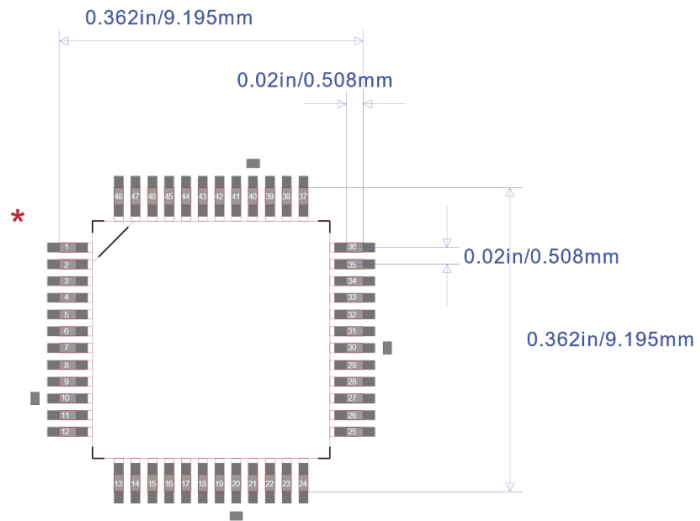

Figure 26 - LQFP48 Package

13.2 LQFP48 PCB Land Pattern



Default Horiz Padstyle: RX11Y48D0T

Default Vert Padstyle: RX11Y48D0T

Alt 1 Padstyle: OX60Y90D30P

Alt 2 Padstyle: OX90Y60D30P

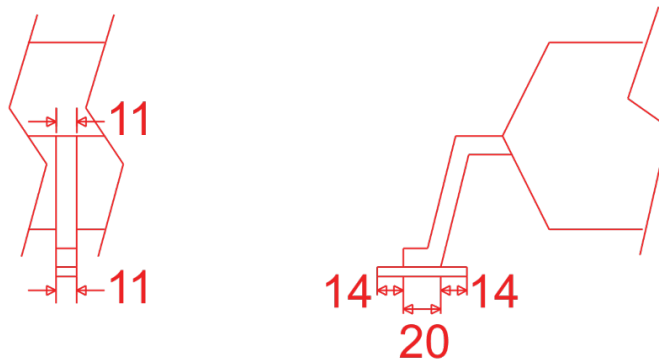

Figure 27 - PCB Land Pattern

13.3 Marking



***** = LOT CODE

= ROM CODE

Figure 28 - Marking

13.4 Soldering Guidelines

The moisture sensitivity level of the FSP201 corresponds to JEDEC Level 3, see also.

IPC/JEDEC J-STD-020C "Joint Industry Standard: Moisture/Reflow Sensitivity Classification for non-hermetic Solid State Surface Mount Devices"

IPC/JEDEC J-STD-033A "Joint Industry Standard: Handling, Packing, Shipping and Use of Moisture/Reflow Sensitive Surface Mount Devices"

The sensor fulfils the lead-free soldering requirements of the above-mentioned IPC/JEDEC standard, i.e., reflow soldering with a peak temperature up to 260°C.

13.5 Compliance

Compliance reports are available upon request.

- RoHS Directive 2011/65/EU + 2015/863/EU
- China RoHS
- Halogen-Free Compliance
- REACH (SVHC) Declaration
- EU Conflict Minerals Declaration
- Other Chemical Substance Information
- MTTF

14 Example Design

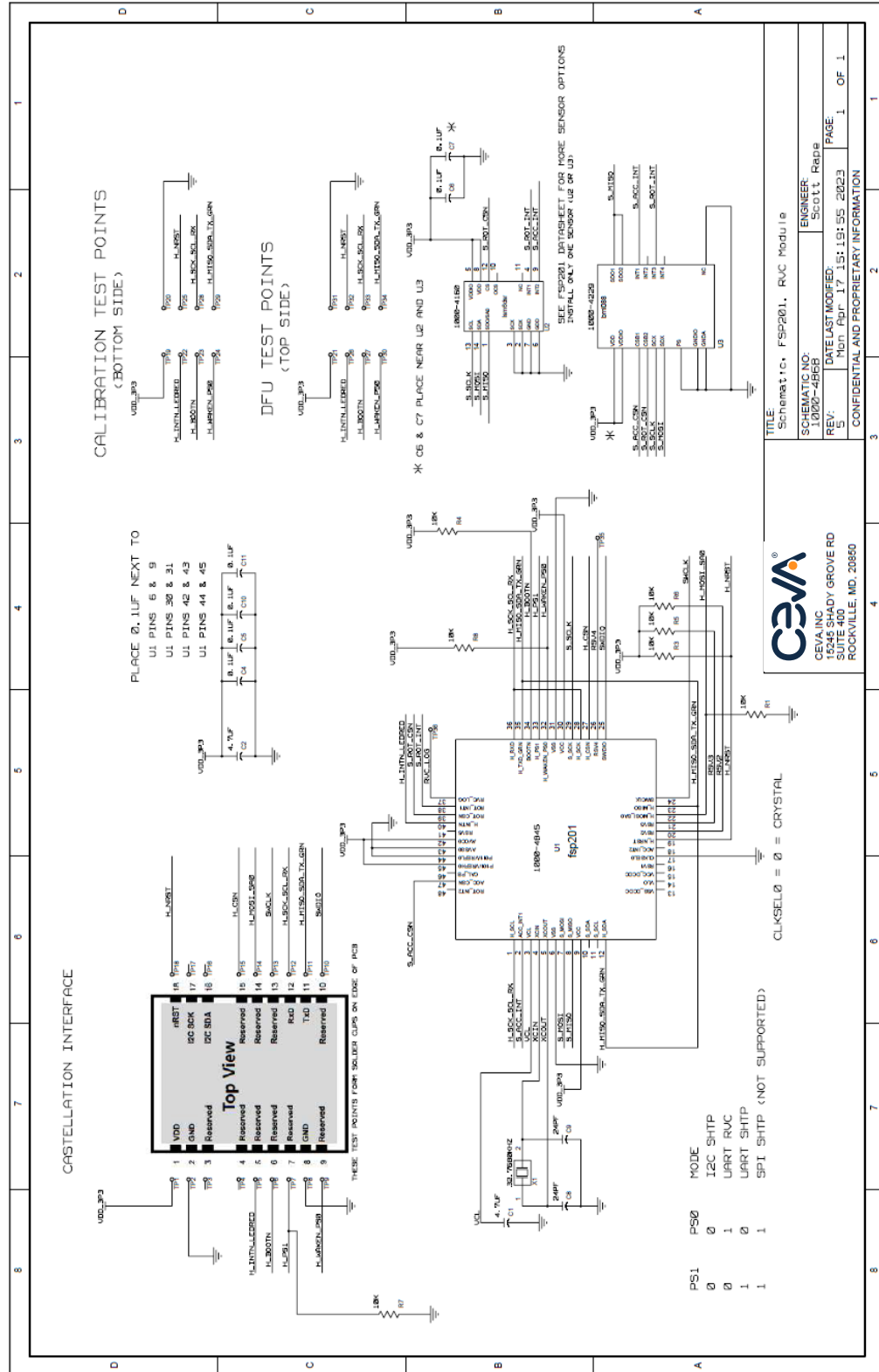

CEVA
 CEVA, INC.
 15045 SHADY GROVE RD
 SUITE 400
 ROCKVILLE, MD, 20850

CEVA
 Schematic: FSP201_RUC Module
 SCHEMATIC NO: 1000-4819
 ENGINEER: SCOTT Rapp
 REV: 5
 DATE LAST MODIFIED: Mon Apr 17 15:15:55 2023
 PAGE 1 OF 1

CONFIDENTIAL AND PROPRIETARY INFORMATION

USA (HQ)

15245 Shady Grove Road
Suite 400
Rockville
MD, 20850
Tel: +1 (240) 308 8328

Israel

7 Hapnina st
Raanana
4321547
Tel: +972 9 961 3700

France

Les Bureaux Green Side 5
400, Avenue Roumanille
06410 Biot
Sophia Antipolis
Tel: +33 4 83 76 06 00

Ceva China

RM1203, Building E
Chamtime Plaza Office,
Lane 2889
Jinke Road, Pudong New
District
Shanghai, 201203, China
Tel: +86-21 20577000

USA (West)

1174 Castro Street
suite 275
Mountain View
CA 94040
Tel: +1 (650) 417 7900

For more information:

