

IT18 Series

COM-HPC® Standard Compatible, Ultra High Density, Low Profile BGA Mezzanine Connector



High-Speed



Low Profile

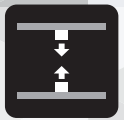

Stacking



Features

1. **COM-HPC® Standard Compatible Connector**
(Version with weld tabs)
2. **High Speed Transmission**
PCIe Gen5(32GT/s), Gen6(64GT/s PAM4),
100Gb Ethernet (4×25Gb)
3. **Low Profile Design**
Available in 5mm and 10mm stacking heights
4. **High Pin Count and Density**
400 positions (0.635mm Pitch)
5. **Open Pin-field Layout**
Flexible pin mapping for various system architectures
6. **Reliable BGA Termination**
Pin-in-ball structure ensures high mounting reliability
7. **Officially Licensed COM-HPC® Connector from Samtec**

Product Specification

Rated Current	0.25A, 1.2A (Note 1)	Operating Temperature (Note 2)	-55 to +125°C
Rated Voltage	150V AC	Storage Temperature (Note 3)	-10 to +60°C

Item	Specifications	Conditions
Contact Resistance	50mΩ Max.	100 mA Max.(DC or 1,000Hz)
Insulation Resistance	5,000MΩ Min.	100V DC
Withstanding Voltage	No insulation breakdown	460V AC for 1min.
Mating Durability	Contact resistance change: 15mΩ Max. No damage, cracks or part dislocation.	100 times
Vibration Resistance	Contact resistance change: 15mΩ Max. No electrical discontinuity of 1 μs Min. No damage, cracks or part dislocation.	Frequency: 50 to 2,000 Hz Power spectral density: 0.04 g ² /Hz For 120h Min. in each of the 3-axis directions
Shock Resistance	Contact resistance change: 15mΩ Max. No electrical discontinuity of 1 μs Min. No damage, cracks or part dislocation.	980m/s ² , Duration of pulse: 6ms 3 times in each of the three mutually orthogonal axes
Thermal Shock	Contact resistance change: 15mΩ Max. Withstanding Voltage: 460V AC Insulation resistance: 5,000MΩ Min. No damage, cracks or part dislocation.	Temperature(°C) -55 → 25 → 85 → 25 Time(min.) 30 → - → 30 → - 100 times
Temperature and Humidity Cycle		25 to 65°C , 240h RH: 90 to 98 %
Heat Resistance	Contact resistance change: 15mΩ Max.	Left at a temperature of 105°C for 250 hours
Nitrate Aeration Test Gas Exposure	Contact resistance change: 15mΩ Max.	Gas Exposure: Nitric Acid Vapor Exposure Duration: 60 min. Drying Temperature: 50°C Measurement: Within 1 hour after exposure

Note 1 : One pin powered per row.

Note 2 : Includes temperature rise due to current flow.

Note 3 : The term "storage" refers to products stored for long period of time prior to mounting and use.

Note 4 : Information contained in this catalog represents general requirements for this Series. Contact us for the drawings and specifications for a specific part number shown.

Materials / Finish

Component	Material	Color / Finish
Insulation	LCP	Natural (Beige)
Contact	Copper Alloy	Contact area: Nickel + Gold Plating Other: Nickel Plating
Solder Ball (BGA)	Sn(96.5)-Ag(3)-Cu(0.5)	-
Retention Tab	Copper Alloy	Nickel + Gold Plating
Metal Cap	Stainless Steel	-

Product Number Structure

Refer to the chart below when determining the product specifications from the product number.
Please select from the product numbers listed in this catalog when placing orders.

■ Receptacle

IT18 - 400 S - BGA ##H

① ② ③ ④ ⑤

① Series Name	IT18	④ Lead Design	BGA
② No. of Pos.	400	⑤ Stacking Height	3.5H: 5mm, 10mm
③ Connector Type	S: Receptacle (Socket)		

■ Plug

IT18 - 400 P - BGA ##H

① ② ③ ④ ⑤

① Series Name	IT18	④ Lead Design	BGA
② No. of Pos.	400	⑤ Stacking Height	1.5H: 5mm 6.5H: 10mm
③ Connector Type	P: Plug		

Signal Integrity

● Pin Assignment

To balance signal integrity and high pin density, the layout shown below is used as the standard configuration.

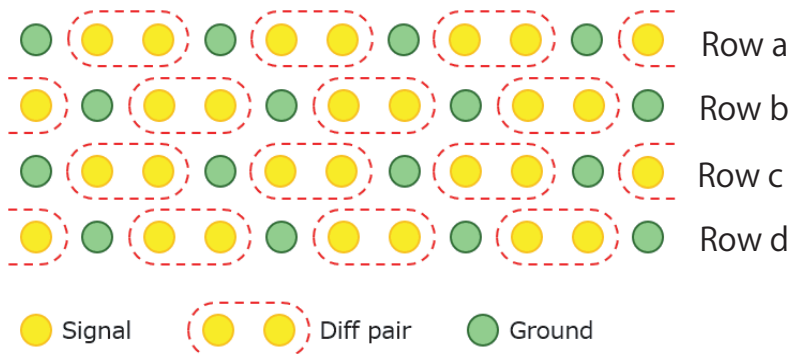

Note 1: The presented data shows the results of analysis based on a reference impedance of 92.5Ω.
 Note 2: The analysis model includes vias and 2.82 mm of trace length (1.41 mm on each side).

● Impedance

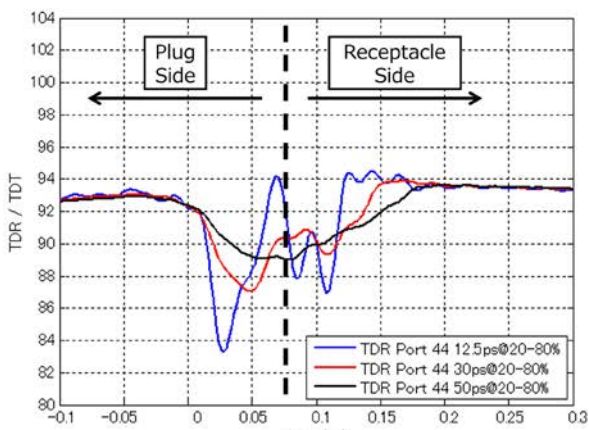

Stacking Height: 5mm

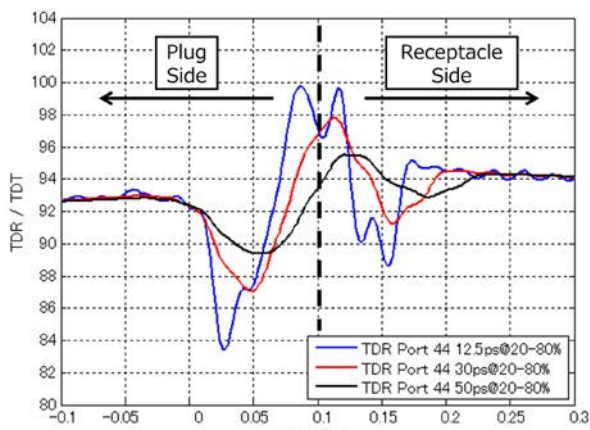

Stacking Height: 10mm

● Insertion Loss and Return Loss

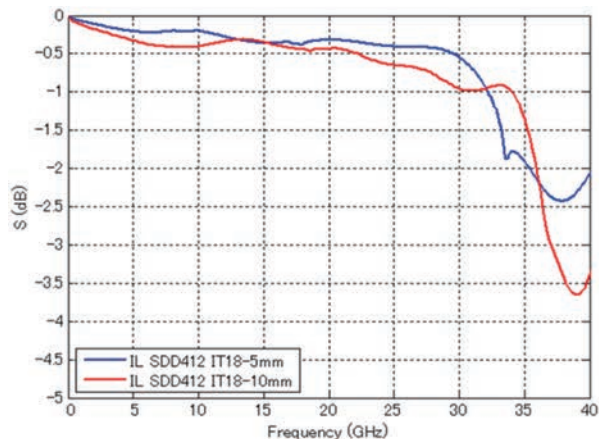

Insertion Loss

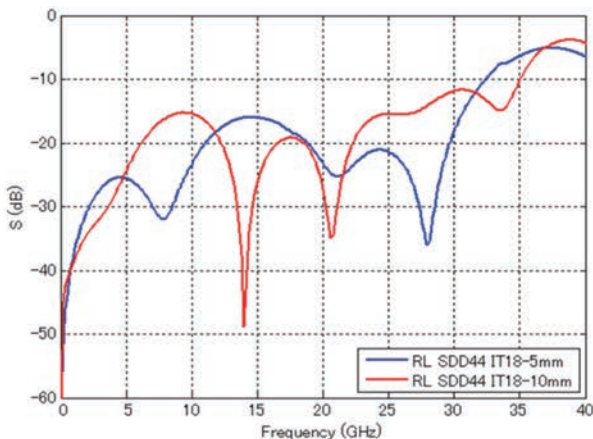

Return Loss

Plug

Stacking Height: 5mm



IT18-400P-BGA-1.5H

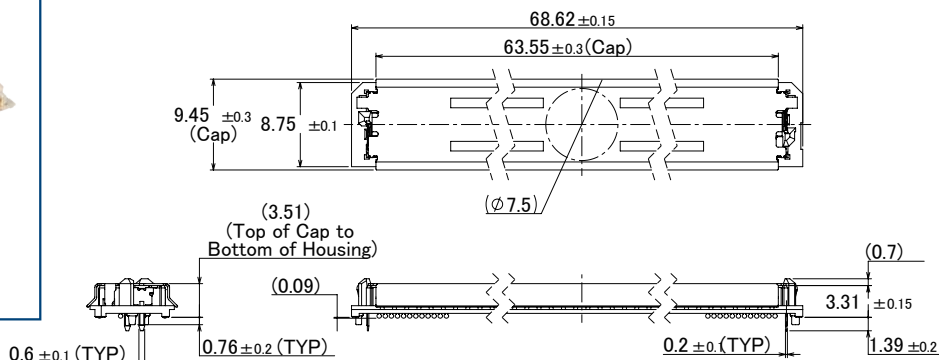

Stacking Height: 10mm



IT18-400P-BGA-6.5H

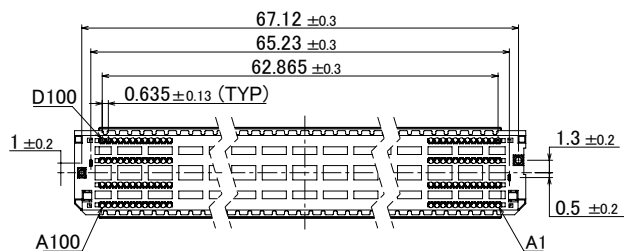

Recommended Land Pattern

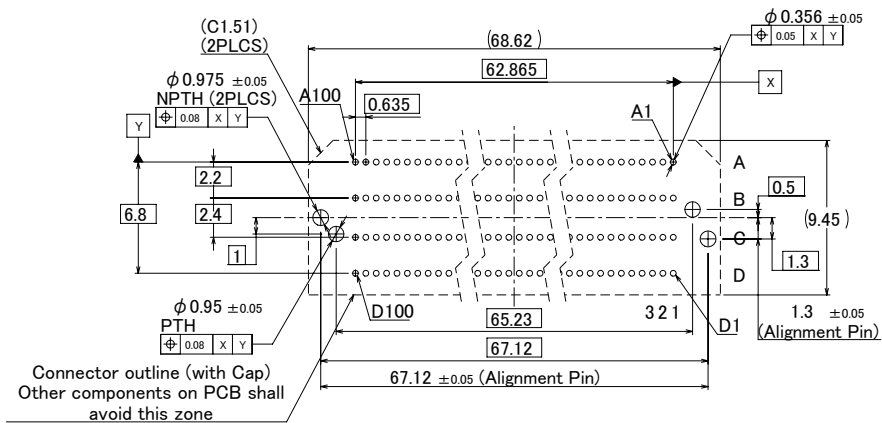

Unit : mm

Part No.	HRS No.	No. of Pos.	A	B	Purchase Unit
IT18-400P-BGA-1.5H	CL0636-8001-0-00	400	3.31	3.51	425pcs per reel
IT18-400P-BGA-6.5H	CL0636-8002-0-00	400	8.31	8.51	150pcs per reel

Part No. Compatibility List

Description	Part No.	HRS No.	Samtec No.	All best No.	Amphenol No.
BGA, Weld Tabs, 0.25 μm Gold	IT18-400P-BGA-1.5H	CL0636-8001-0-00	ASP-230333-01	R-CM-HPC400-8AW1-FS103	10171123-14340T1LF
BGA, Weld Tabs, 0.25 μm Gold	IT18-400P-BGA-6.5H	CL0636-8002-0-00	ASP-230336-01	R-CM-HPC400-8AW2-FS103	10171123-14840T1LF
BGA, Weld Tabs, 0.25 μm Gold	IT18-400S-BGA-3.5H	CL0636-8003-0-00	ASP-230332-01	R-CF-HPC400-8AW1-FS103	10171124-14373T1LF

Mating Operation

● Mating Self-Alignment Tolerance

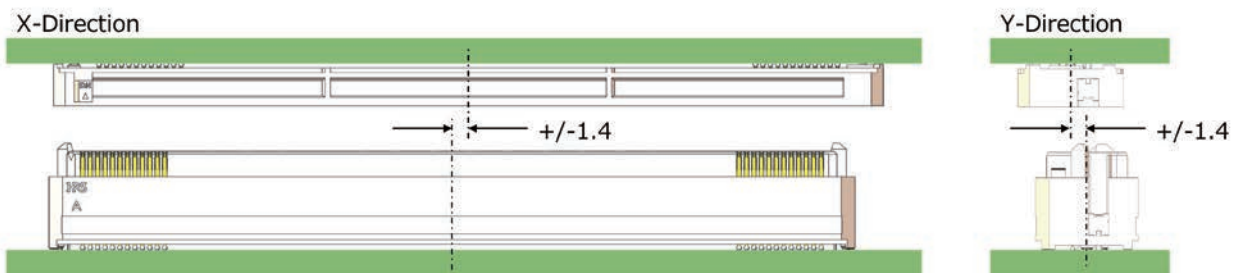

● Mating Position Misalignment Tolerance

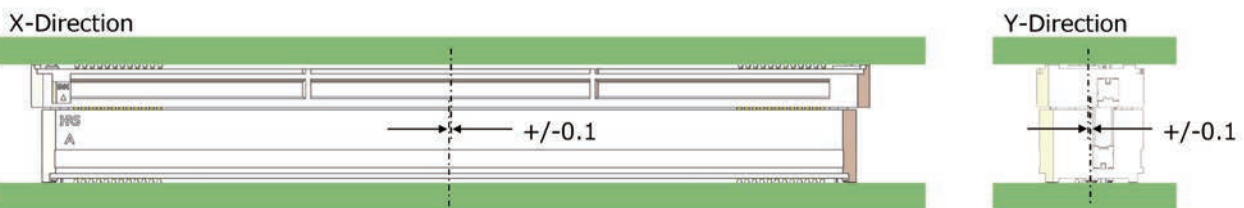

Mounting Temperature Profile (Reference)

● Pb-Free Assembly

Preheat / Soak [T_s] (150 to 200°C)	Max. Ramp Up Rate	Reflow Time [T_L] (217°C Min.)	Peak Temperature [T_p]	Peak Temperature Time [T_p]	Cooling Rate	Time Between Room Temperature and Peak
60 - 120 sec.	3°C Max./s	40 - 150 sec.	260°C	30 sec. Max.	6°C Max./s	8min. Max

Recommended Temperature Profile

The appropriate temperature profile may vary depending on solder paste type, manufacturer, PCB size, and other soldering materials. Please verify mounting conditions thoroughly before use.

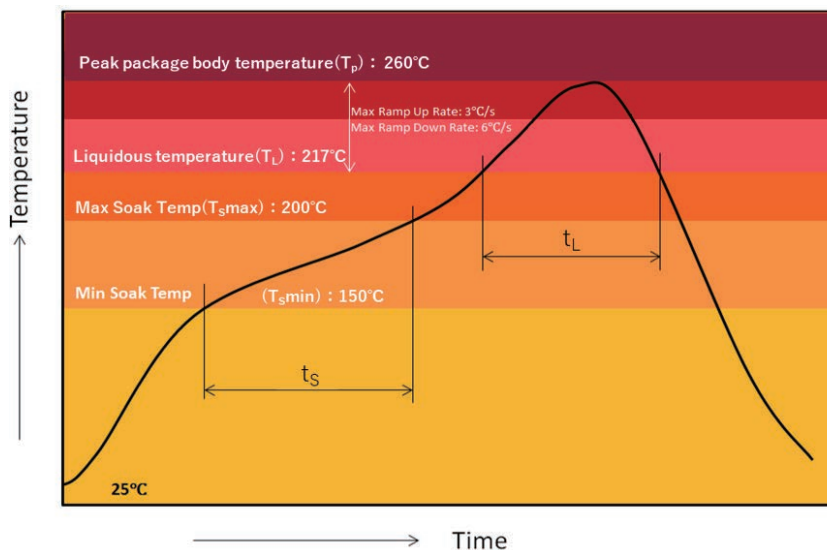

While Taking into Consideration

Specifications mentioned in this catalog are reference values.

When considering to order or use this product, please review the Drawing and Product Specifications sheets.

Use an appropriate cable when using the connector in combination with cables.

If considering usage of a non-specified cable, please contact your sales representative.

If assembly process is done by jigs & tools which are not identified by Hirose, the warranty of the product may be affected.

If considering usage for below mentioned applications, please contact your sales representative.

In cases where the application will demand a high level of reliability, such as automotive, medical instruments, public infrastructure, aerospace/defense etc. Hirose must review before assurance of reliability can be given.